

STREAMLINE

EXTRUSION DIES

Model SR-2.0

The StreamLine® Series SR Spiral In-Line Style Extrusion Dies for tube, pipe and hose products have many of the quality design features that make StreamLine design, engineering and manufacturing world famous. Many sizes are available up to 12" die bushing capacity. Larger custom design sizes are also available.

Rugged Construction

- Carpenter Custom 630™ (17-4PH) stainless steel, heat treated to 44 Rc and chemically passivated.
- High strength and superior surface finish durability.
- Polymer flow surfaces polished to 8 micro-inch surface finish.
- Other special metals and surface treatments available upon request.

Radial Weld Lines Eliminated

- Product weld lines completely eliminated with proven blown-film spiral manifold melt distribution technology.
- Partial helical orientation imparted to the melt flow.
- Extruded product aesthetics are greatly improved.
- Physical properties of the extruded product, especially burst pressure, are increased.

Low Polymer Volume

- Smooth, profiled and polished polymer flow paths reduce traditional areas of melt stagnation.
- Conical breaker plates replace flat breaker plates, reducing polymer volume and melt degradation.
- Non-intrusive melt thermocouple is designed into polymer melt stream to monitor melt temperature without polymer flow disruption or degradation.
- Pressure and temperature transducer ports designed as replaceable inserts to extend die life.

Precision Operator Adjustment

- Innovative dual-thread die centering mechanism provides unequalled product wall centering in an in-line extrusion head.

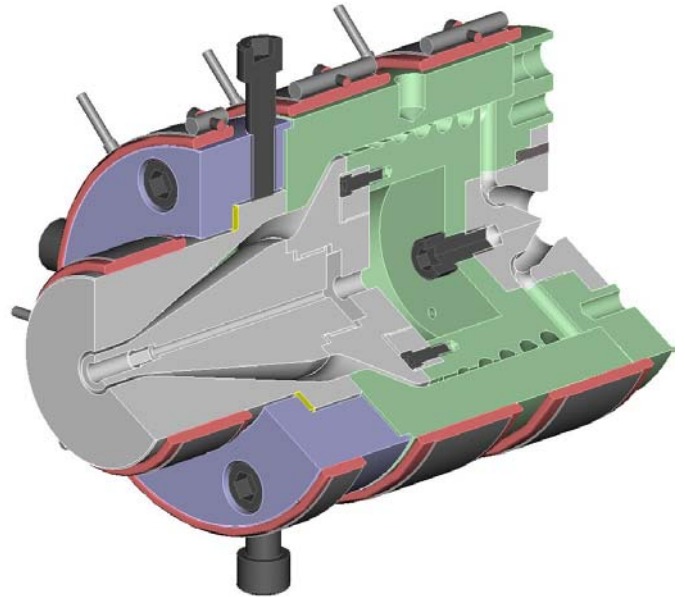

- Stepped and shouldered hex drive connections furnish hassle-free adjuster wrench use.

Easy Maintenance

- Complete, detailed and illustrated instructions for assembly, disassembly, preventative maintenance and cleaning are provided.
- 240V band heaters, J-type thermocouples, bayonet adapters, and disassembly tools are included.
- Jacking threads built into precision diameter interfaces to ease operator disassembly.
- Metric fastener option for metric production environments.
- Sealing surfaces accessible for refinishing.
- Bolt flange and clamp flange versions are available.
- High temperature, Grade 8 fasteners are standard.
- The clamping flange is designed as a replaceable component.

Family Members

This family of heads is defined by the maximum die opening in the head assembly.

SR-0.5, ½" maximum die bushing inner diameter.

SR-1.0, 1" maximum die bushing inner diameter.

SR-2.0, 2" maximum die bushing inner diameter.

SR-3.0, 3" maximum die bushing inner diameter.

SR-4.0, 4" maximum die bushing inner diameter.

Other larger sizes available upon request.

Our continual program of product and process improvement may necessitate, without notice, changes in the specifications and data contained herein.